

AuRiCo

(Automatic Rig Control)

Installation & operation manual

AuRiCo was mainly developed to control servos on a KAP-Rig
 In most cases servos are controlled by RC, this is not necessary with AuRiCo.
 You can rotate and tilt the rig in predefined intervals and also take pictures using a shutter servo. Using a camera in intervalmode is also possible.

Attention:

***The developement of the electronics and the program was mainly done as a hobby project, and so it should be seen.
 The useage of this hardware in medical or industrial applications is not allowed.***

I will not take over any responsibilities for human or material damages, which occur while using this hardware.

AuRiCo Functions:

AuRiCo automatically rotates and tilts a camera which is mounted on a Kap-Rig to make Kite Aerial photos. These movement intervals are widely adjustable.
 Normal RC servos are used to do the rotation, tilt & shutter release and can be directly connected to the controller. Most standart servo systems are supported.
 The fotos are taken by the shutter servo, or can be taken automatically by the camera if has an interval mode.
 The Panservo has to be modified for 360° operation, or use a Parallax CRS servo.

AuRiCo Features:

Small industrial manufactured PCB (43mm*36mm).
 Controlled by a Risc Microcontroller.
 Servo connectors compatible with Graupner, Futaba & Conrad (Profi) System.
 Powersupply: 3.6V – 6V (4 x AA oder AAA cells (recommended) or 1 Lipo Cell)
 Very low power consumption, long battery or accu cycles
 Servo control via PWM.
 Configuration via Dip-switches (no programming needed)
 Updatable with newer software releases.
 Rotation-angle & intervals widely adjustable.
 Digicams with interval mode can be used.
 Shutter release via servo possible.
 4 modes with different tilt angles (dependant on Rig).
 2 additionsl Turbo Modes available
 Special Adjust Mode available for easy servo adjustment

How to connect AuRiCo:

AuRiCo has servo plugs which are compatible to the Graupner, Futaba and Profi (Conrad) standard systems.

While plugging in the servo / battery connectors be aware to use the right direction / polarity (look at the picture) otherwise parts can be damaged (esp. your servos)

If you want to use other servos which are not compatible, you can use adaptors, or you can solder plugs to the cables which fit. .

The pan servo has to be modified for 360° operation, or use a Parallax CRS servo.

The picture shows how to connect the servos & power correctly:

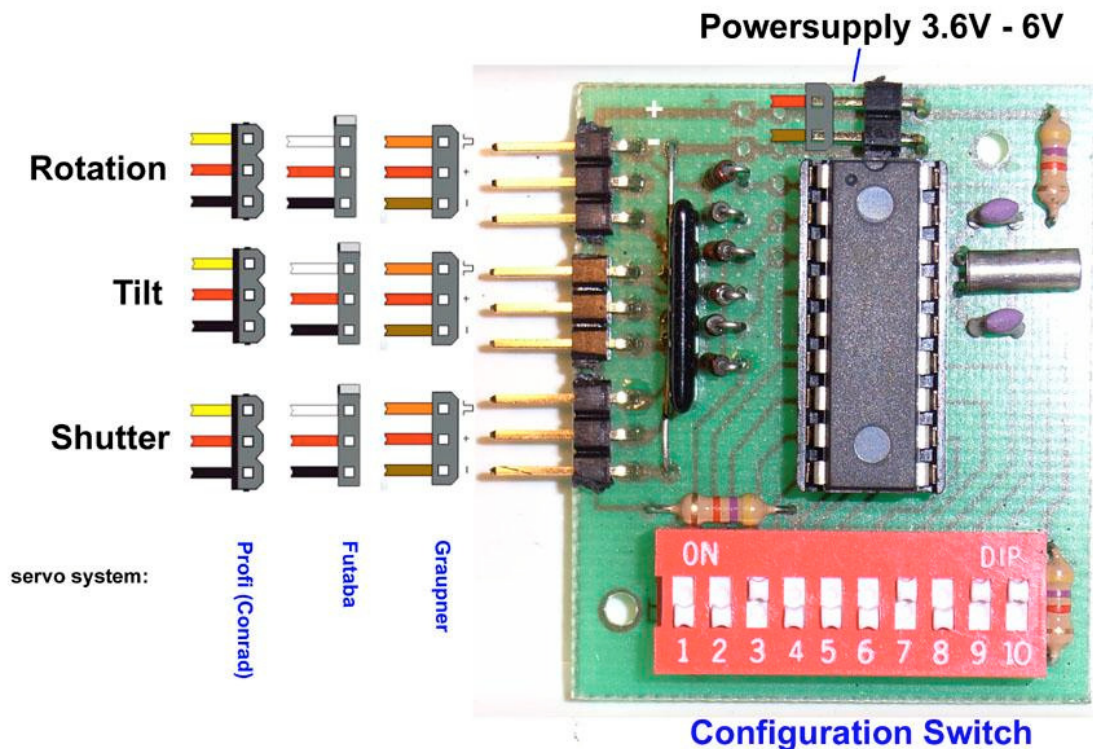

Configuration:

AuRiCo configuration can be done in an easy way via 10 Dip switches. The switches are combined in groups, the functions will be explained in the following chapters:

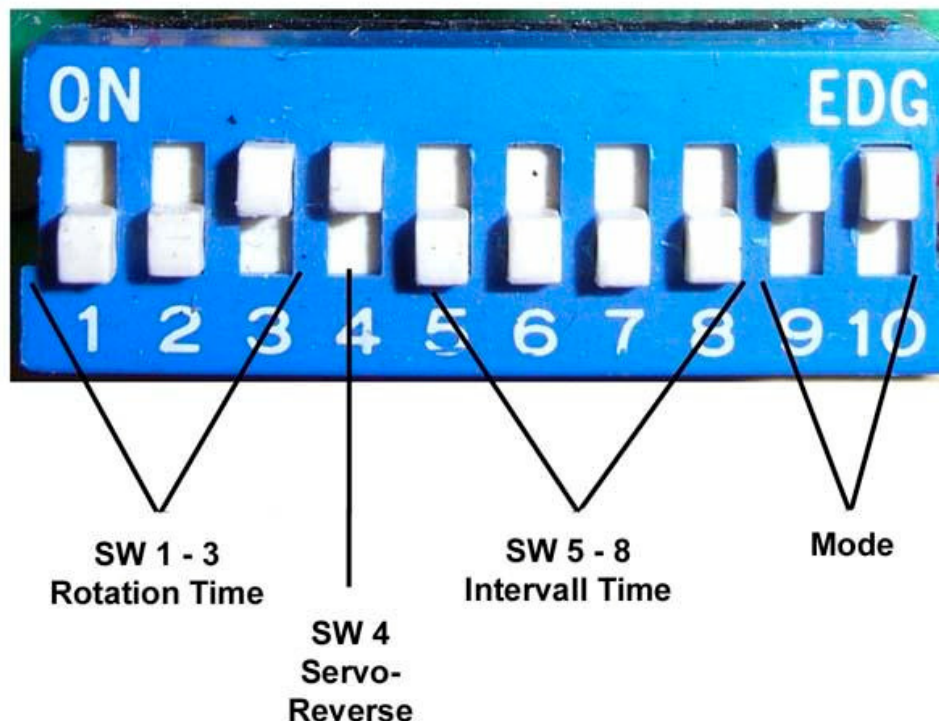
**SW1 – SW3 (rotation time)**

This 3 switches control the time in which the pan servo is active, this means they control the angle of the Rig rotation per interval. You have to try out the right time for your favorite angle as it depends on the gear you use and the speed of the servo. My proposal is a 1:4 gear between servo & rotor axis.

SW1	SW2	SW3	time of rotation
OFF	OFF	OFF	0,2 sec
OFF	OFF	ON	0,4 sec
OFF	ON	OFF	0,5 sec
OFF	ON	ON	0,6 sec
ON	OFF	OFF	0,7 sec
ON	OFF	ON	0,9 sec
ON	ON	OFF	1,1 sec
ON	ON	ON	1,3 sec

SW4 (servo reverse)

This switch reverses the movement of the shutter & tilt servos (right ← → left)

SW5 – SW8 (interval)

SW5 – SW8 control the interval time, it can be adjusted between 5sec and 240secs. The interval time is the time between rotation moves (Mode 0) or between the tilt moves in Modes 1-3. The last 3 combinations activate 2 special Turbo Modes or the Adjust Mode. (see below)

SW5	SW6	SW7	SW8	Interval
OFF	OFF	OFF	OFF	5 sec
OFF	OFF	OFF	ON	10 sec
OFF	OFF	ON	OFF	15 sec
OFF	OFF	ON	ON	20 sec
OFF	ON	OFF	OFF	30 sec
OFF	ON	OFF	ON	45 sec
OFF	ON	ON	OFF	60 sec
OFF	ON	ON	ON	90 sec
ON	OFF	OFF	OFF	120 sec
ON	OFF	OFF	ON	150 sec
ON	OFF	ON	OFF	180 sec
ON	OFF	ON	ON	210 sec
ON	ON	OFF	OFF	240 sec
ON	ON	OFF	ON	Adjust Mode
ON	ON	ON	OFF	Turbo 3 sec
ON	ON	ON	ON	Turbo 2 sec

SW9 – SW10 (Mode)

SW9 & SW10 control the different modes of AuRiCo. 4 different modes are available:

SW9	SW10	Mode
OFF	OFF	0
OFF	ON	1
ON	OFF	2
ON	ON	3

Mode 0:

The tilt angle is fixed, 1 rotation step per interval, 1 release of the shutter servo. In this Mode a tilt servo is not needed (not activated)

Mode 1:

2 tilt positions / interval (15° & 45°) with 1 picture (shutter release)

Mode 2:

3 tilts positions / interval (15°, 45°, 70°) with 1 picture (shutter release)

Mode 3:

4 tilts positions / interval (0°, 15°, 45°, 70°) with 1 picture (shutter release)

In Mode 1-3 the rotation is done after the last tilt. This means: 2-4 pictures are taken in different tilt positions but in the same rotation angle.

Turbo Mode

The 2 Modes are for fast intervals (2sek & 3 sek) with rotation. The modes were implemented on request from a kaper to take many pictures with small rotation to be able to assemble the pictures to panoramas later.

SW5	SW6	SW7	SW8	
ON	ON	ON	OFF	Turbo 3sek
ON	ON	ON	ON	Turbo 2sek

SW9 & SW10 are disabled in turbo mode: turbo mode works automatically in mode 0 (rotation only without tilt. The tilt angle has to be adjusted and fixed manually. SW1-3 do control the rotation time (angle) as usual.

Turbo mode does not fit to all cameras, as some (older) cameras need more time to take and store the pictures.

If AuRiCo is powered on in one of the turbo modes the startup sequence will change:

10 secs after power on the shutter & tilt servos will drive into the neutral position, after another 10 sec the shutter servo is activated 3 times (this is for checking the shutter servo mechanic)

After this a 4min delay without any action is started. During this delay you can start and position your kite without taking a lot of unuseable pictures. After the delay AuRiCo starts taking pictures via shutter servo with 2 or 3 sec intervals.

Adjust Mode

In Adjust Mode you can manually drive the shutter & tilt servos into all used positions the positions & servos are controlled by SW1-3 (see below). This mode is very usefull for adjusting the servos (esp. the shutter servo)

You can activate this mode at any time during normal operation. The mode will become active after the currently running interval is finished.

If AuRiCo is powered up in Adjust Mode, the 20sec startup delay is not executed: you can immediately start positioning the Servos.

SW1-3 control the following functions in Adjust Mode:

SW1	SW2	SW3	servo / position
OFF	ON	OFF	Shutter servo neutral
OFF	ON	ON	Shutter servo prefokus
ON	ON	OFF	Shuter servo full release
OFF	OFF	OFF	Tilt servo 0°
OFF	OFF	ON	Tilt servo 15°
ON	OFF	OFF	Tilt servo 45°
ON	OFF	ON	Tilt servo 60°
ON	ON	ON	Both servos off

Operation:

After the power is on, a system init is done, and AuRiCo drives the tilt and shutter servo into the middle position after a 10 secs delay, now you can shut off the power, and you can do adjustments to the mechanic if needed.

After another 10 secs the config switches are read in, and the first interval starts with a rotation. After each interval (depending on the active mode & interval time) the switches are read again. So you can quickly change modes & times just as you need.

The startup sequence changes in Turbo Mode or Adjust Mode (see above)

Tip: *to test the rotation, tilts & shutter releases an interval time of 5 or 10 sec is usefull.*

Cameras with interval mode:

If you are using a camera in interval mode you have to set the intervals of the camera and AuRiCo to equal times. Best thing is to start the camera Interval in the middle of AuRiCo's interval cycle. Camera and AuRiCo are synchronized now!

Shutter servo:

2 secs. after the tilt motion (after rotation in Mode 0) the shutter servo drives to a 60° position, and stays there for 0.5 second (pre-focus) after the „pre-focus-time the servo drives further for approx 10° to do the release (the picture is taken) After another 1/2 sec the servo drives back to the neutral position.

Tilt servo:

In Mode 1 - 3 the tilt servo drives to the next position (15°, 45°, 60°, 0°) after the interval time is over

Power supply:

You can use 4 x AAA (Micro) accus or Alkaline cells to power the system. Powering is also possible with 1 Lipo cell, but ensure that the servos are strong enough at 3.6 Volt supply.

A non stop test with 4 AAA Alkaline batteries and 10 sec interval time in Mode 3 ended up after 24hrs operation time !!

[Much more informations and tips about KAP can be found in the internet. Use your favorite search engine to find it.](#)

Have much fun with this controller and your Auto-Rig.

I'll enjoy every photo & comment / suggestion which are sent to me via eMail

Peter Engels (eMail: engelspj@t-online.de) <http://skyware.fam-engels.de>

History:

- v1.3 Turbo Mode & Adjust Mode implemented
- v1.2 Servo reverse with SW4 - 1. Official version
- v1.1 extension to 4 modes + optimized servo-trigger
- v1.0 1st error-free version with 2 modes

You can find infos on software updates, tips & tricks at:

<http://skyware.fam-engels.de> (click on the **AuRiCo** entry)

plugs & color codes of supported servo systems:

